

Operating Instructions  
**Electric contact gauge**  
**KL 010/KL 010 TM**

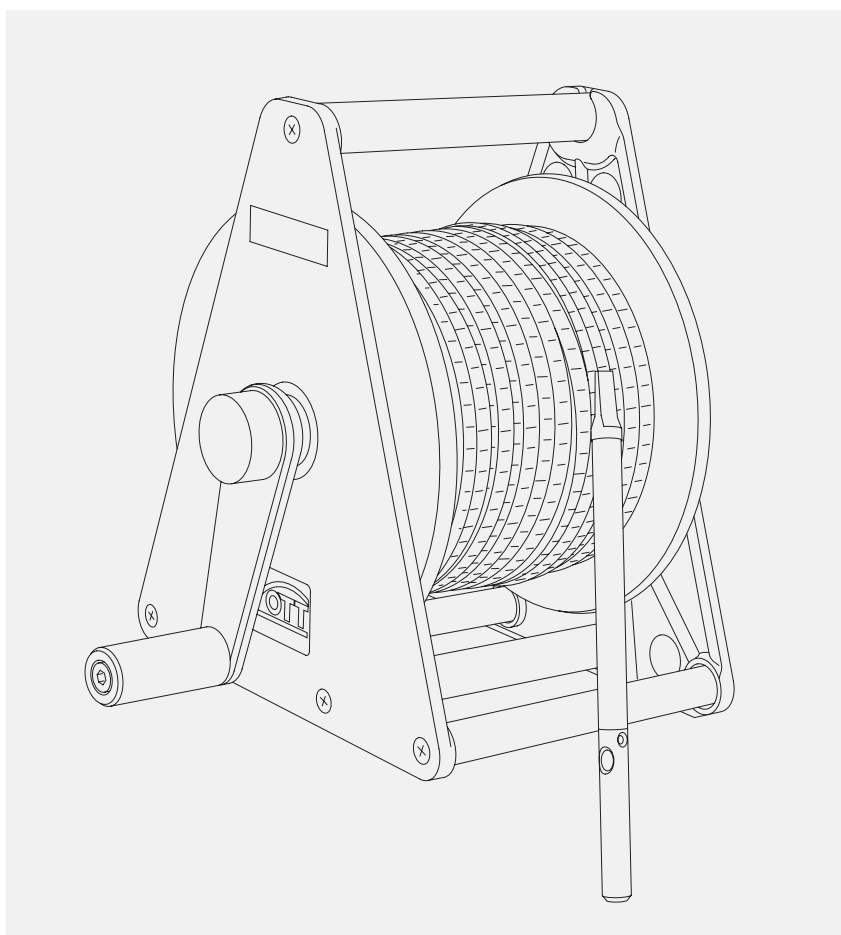

## Delivery scope

- ▶ **KL 010**
  - 1 Electric contact gauge for measuring the water level
  - 4 1.5 V batteries; type: LR 14 C AM 2
  - 1 operating instructions
- ▶ **KL 010 TM**
  - 1 Electric contact gauge for measuring the water level and the water temperature
  - 4 1.5 V batteries; type: LR 14 C AM 2
  - 1 operating instructions

## Order numbers

▶ <b>KL 010</b>	<b>Electric contact gauge</b>	
	- 15 m	24.320.015.9.5
	- 25 m	24.320.025.9.5
	- 30 m	24.320.030.9.5
	- 50 m	24.320.050.9.5
	- 80 m	24.320.080.9.5
	- 100 m	24.320.100.9.5
	- 150 m	24.320.150.9.5
	- 200 m	24.320.200.9.5
	- 250 m	24.320.250.9.5
	- 300 m	24.320.300.9.5
- 500 m	24.320.500.9.5	
- 750 m	24.320.750.9.5	
<b>KL 010 TM</b>	<b>Electric contact gauge</b>	
	- 25 m (design 1)	24.321.025.9.5
	- 50 m (design 1)	24.321.050.9.5
	- 100 m (design 1)	24.321.100.9.5
	- 150 m (design 2)	24.321.150.9.5
	- 200 m (design 2)	24.321.200.9.5
	- 250 m (design 2)	24.321.250.9.5
	- 300 m (design 2)	24.321.300.9.5
- 500 m (design 2)	24.321.500.9.5	
▶ <b>Accessories</b>	<b>Protective carrier KL 010</b>	24.110.041.4.5
	- made of coated nylon	
	<b>Protective carrier KL 010 TM</b>	24.110.040.4.5
	- small; for design 1; up to 100 m of measuring tape - made of coated nylon	
	<b>Protective carrier KL 010 TM</b>	24.110.041.4.5
	- large; for design 2; from 150 m of measuring tape - made of coated nylon	
	<b>Ground contact for KL 010</b>	24.310.009.9.5
	- for measuring the depth of a drilled hole	
▶ <b>Replacement parts</b>	<b>Measuring tape KL 010</b>	24.310.001.9.5
	- including measuring probe - Lengths as specified above	
	<b>Measuring tape KL 010 TM</b>	24.311.001.9.5
	- including measuring probe - Lengths as specified above	
	<b>Measuring probe weight KL 010</b>	24.310.004.9.5
	<b>Protective cage for measuring probe KL 010 TM</b>	on request

## Introduction

The electric contact gauges KL 010 and KL 010 TM are used for fast and accurate measurements of water levels in groundwater areas.

They are suitable for both control measurements, e.g. in level pipes or well shafts (descent measurements), as well as for continuous monitoring of pump tests.

The electric contact gauge KL 010 TM is also equipped with a temperature sensor and an LCD display (Liquid Crystal Display).

As a special application, level determinations of electrically conducting liquids are possible in any type of container.

### KL 010

- ▶ Water level measurement
- ▶ Measuring range 15 m to 750 m
- ▶ Signal lamp and acoustic signal generator
- ▶ Ground contact (Accessories): determination of depth in level pipes

### KL 010 TM

- ▶ Measurement of water level and water temperature
- ▶ Measuring range 25 m to 500 m
- ▶ LCD display and acoustic signal generator

Fig. 1: Electric contact gauges KL 010 and KL 010 TM.

Two designs of the KL 010 TM electric contact gauge are available:  
Design 1 for measuring tape lengths of 25 m, 50 m and 100 m;  
Design 2: from a measuring tape length of 150 m.

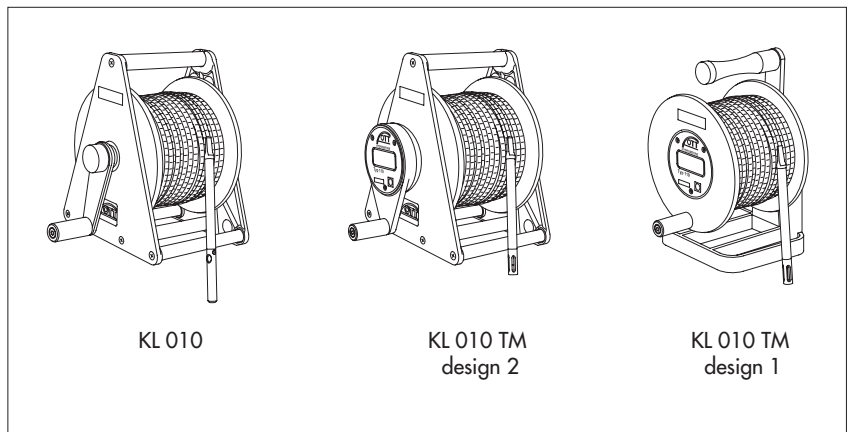

## Taking the unit into operation

No special work is required to take the unit into operation. OTT supplies the KL 010 and KL 010 TM electric contact gauges ready for use with the batteries already fitted. You can leave the batteries in the unit between measurements. The electric contact gauges switch off automatically after the measurements.

We recommend removing the batteries when the unit is to be put into storage for a long time (even with high quality batteries there is a risk that they might leak).

## Performing a descent measurement



### Safety information

- ▶ The electric contact gauge must only be used for measurements in water or aqueous liquids (hydrometry). Do not use the electric contact gauge in combustible liquids!
- ▶ Take care to avoid contamination of the groundwater when using an electric contact gauge!
- ▶ Do not kink the measuring tape - risk of breakage!

### Proceed as follows to perform a descent measurement:

- ▶ Undo the star grip bolt (transport retainer).
- ▶ Lower the measuring tape with the measuring probe by means of the crank lever, into for example the level pipe.
  - **KL 010:** When the measuring probe touches the water level an acoustic signal sounds and the signal lamp on the side of the frame lights up.
  - **KL 010 TM:** When the measuring probe touches the water an acoustic signal sounds for approx. 5 seconds and the LCD display displays the temperature value. Temperature profiles can be built up by lowering the measuring probe further.
- ▶ Move the measuring tape up and down by a few centimetres to locate the precise water level. The distance between the reference level (e.g. the upper edge of the pipe or shaft cover) and the water level can be read off the measuring tape in metres and centimetres.
- ▶ Pull the measuring tape with the measuring probe back out of the level pipe by means of the crank lever. (Clean the measuring tape/measuring probe as required, see Maintenance)
- ▶ Put the measuring probe in the holder for storage.
- ▶ Tighten the star grip bolt.

Fig. 2: Application example – descent measurement with the KL 010 electric contact gauge.

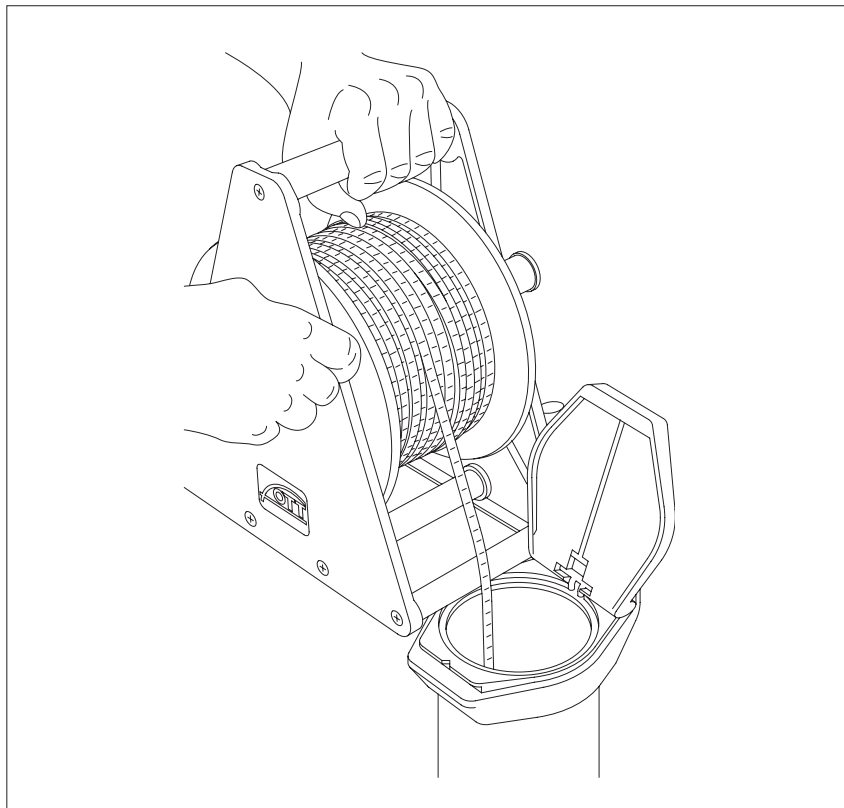

## Determining the depth of a drilled hole (with the ground contact accessory)

With the aid of a ground contact (accessory for KL 010), it is also possible to determine the depth of drilled holes or level pipes in addition to performing descent measurements. For this purpose the ground contact should be installed on the measuring probe instead of the measuring probe weight.

### Proceed as follows to install the ground contact:

- Unscrew the measuring probe weight (lower part of the measuring probe).
- Screw on the ground contact.

Fig. 3: Installation of the base probe on the measuring probe.

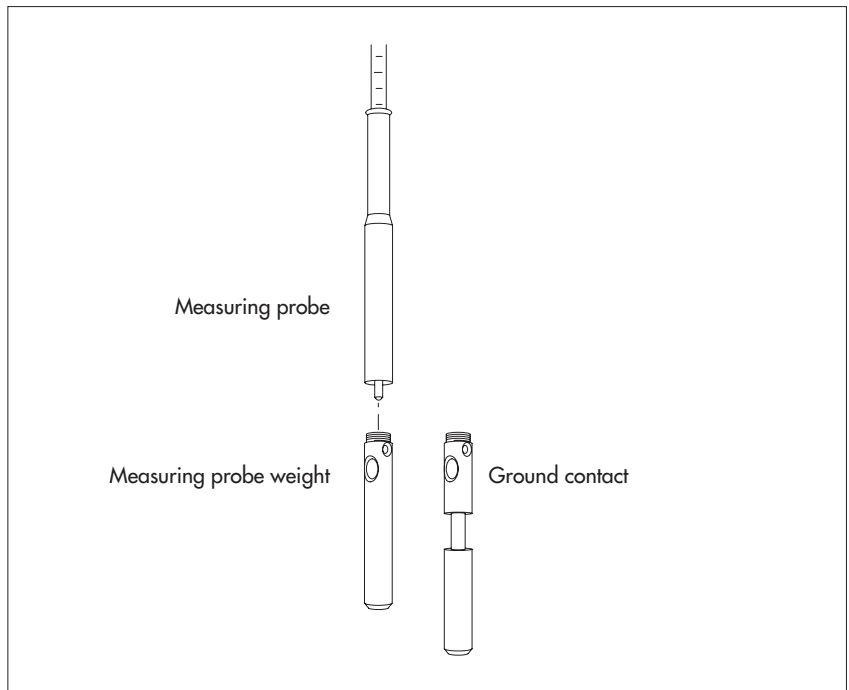

### Proceed as follows to determine the depth of a drilled hole:

- ▶ Undo the star grip bolt (transport retainer).
- ▶ Lower the measuring probe on the measuring tape by means of the crank handle, for example into the drilled hole. → When the measuring probe touches the water level an acoustic signal sounds and the signal lamp on the side of the from lights up (descent measurement). Lower the measuring probe further. As soon as the ground contact touches the bottom of the drilled hole the signal lamp goes out and the acoustic signal stops → the depth of the drilled hole has been successfully determined. The distance between the reference level (e.g. the upper edge of the cover of the pipe or shaft) and the bottom of the drilled hole can be read off the measuring tape in metres and centimetres.
- ▶ Pull the measuring tape with the measuring probe back out of the drilled hole by means of the crank lever. (Clean the measuring tape/measuring probe as required, see Maintenance)
- ▶ Put the measuring probe in the holder for storage.
- ▶ Tighten the star grip bolt.

## Cleaning the electric contact gauge

- Clean the measuring tape at regular intervals, depending on how dirty it is. To do this simply wipe it clean with water or a soap solution.
- After unscrewing the measuring probe weight, clean any contamination and limescale from the electrodes. Use a gentle limescale remover for this purpose.

After use of the electric contact gauge in heavily contaminated water (e.g. leakage water in the area of domestic waste sites):

- Thoroughly rinse the measuring tape and the measuring probe with clear water.

## Changing the batteries



**Caution:** Dispose of the old batteries carefully. Batteries must never be discarded as normal waste.

**Proceed as follows to change the batteries (see Fig. 4):**

### KL 010

When the batteries are used up the brightness of the signal lamp and the volume of the acoustic signal are reduced during measurements.

- Unscrew and remove the screw cap.
- Remove the used batteries.
- **Caution:** Observe the correct polarity when inserting the batteries. Insert four new 1.5 V batteries (size: LR 14 C AM 2) into the battery compartment. All of the positive terminals should face towards the screw cap.
- Fasten screw cap.
- The contact gauge is operative.

### KL 010 TM

Checking the battery capacity:

- Press the “%” button → the LCD display shows the remaining available battery capacity in %. Recommendation: The batteries should be replaced as soon as the battery capacity is  $\leq 25\%$ . At ambient temperatures below this 0 °C should happen accordingly sooner.

Changing the batteries on design 1

- Unscrew and remove both screw caps.
- Remove the used batteries.
- **Caution:** Observe the correct polarity of the batteries. Insert two pairs of two new 1.5 V batteries (size LR 14 C AM 2) into the battery compartments. All of the positive terminals should face towards the screw cap.
- Fasten both screw caps.

Changing the batteries on design 2

- Unscrew and remove the screw cap.
- Remove the used batteries.
- **Caution:** Observe the correct polarity when inserting the batteries. Insert four new 1.5 V batteries (size: LR 14 C AM 2) into the battery compartment. All of the positive terminals should face towards the screw cap.
- Fasten screw cap.
- An acoustic tone lasting approx. 5 seconds indicates that the electric contact gauge is ready for operation. The LCD display shows the available battery capacity in % during this time.

Fig. 4: Changing the batteries.

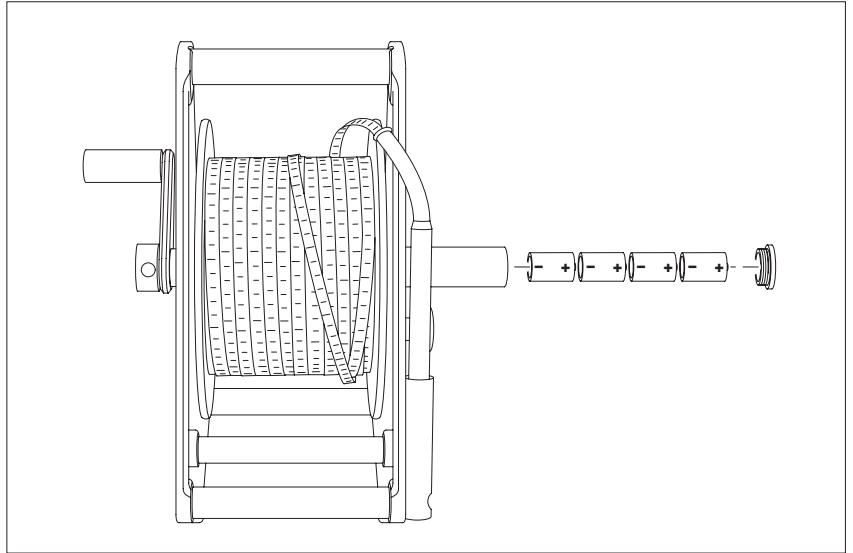

## Troubleshooting

During troubleshooting, test the electric contact gauge in a suitable container with clear tap water.

### KL 010

- ▶ Signal lamp dim, quiet acoustic tone  
The batteries are nearly used up → change the batteries.
- ▶ Signal lamp not lit up, no acoustic tone  
The batteries are completely used up → change the batteries.
- ▶ Signal lamp not lit up, acoustic tone present  
Signal lamp defective → change the signal lamp (E10 / 5 V / 0.15 A).

### KL 010 TM

- ▶ The LCD display does not show a temperature value, there is no signal tone (pressing the "%" button also fails to display a value for the battery capacity)  
The batteries are completely used up → change the batteries.

In the event of any other fault or if the electric contact gauge is damaged then have the electric contact gauge → checked and repaired by the service department of OTT.

## Technical data

Measuring tape	
Type	2-stranded; conductor made of high-strength rust-proof and acid-proof steel strands
Material	Polyethylene (white)
Labelling	Metre scale: red; cm divisions (1 cm = narrow line, 5 cm = broad line) and dm numbers (10 cm): black
Measuring accuracy	0.1 % of the measured value
Drum material	Special plastic; high-strength, resistant to low temperatures
Frame material:	cast aluminium; plastic-coated
Power supply	6 V DC; 4 batteries size: 1,5 V: LR 14 C AM 2; alkali-manganese type; length of use at least 12 months
Operating temperature range	-30 °C ... +75 °C

### KL 010

Measuring ranges (measuring tape length)	15 m ... 750 m (12 levels)
Signalling	Signal lamp/acoustic signal generator
Measuring probe	
Material	non-rusting steel/nickel-plated brass
Diameter	15 mm
Length	190 mm (incl. 225 mm kinking protection)
Weight	approx. 3.8 kg (15 m) ... approx. 18.5 kg (750 m)

### KL 010 TM

Measuring ranges (measuring tape length)	25 m ... 500 m (8 levels)
Signalling	LCD/acoustic signal generator
Temperature sensor	
Measuring range	-5 °C ... +60 °C
Measuring accuracy	± 0.1 °C
Measuring probe	
Material	non-rusting steel/nickel-plated brass
Diameter	15 mm
Length	183 mm (incl. 228 mm kinking protection)
Display	
LCD	3 1/2-digit
Resolution	0.1 °C
Battery monitoring	Button to display the battery capacity in %
Weight	approx. 3.6 kg (25 m) ... approx. 14.3 kg (500 m)

## OTT MESSTECHNIK GmbH & Co. KG

Ludwigstrasse 16  
87437 Kempten • Germany  
Tel. +49 (0)8 31 / 56 17-0  
Fax +49 (0)8 31 / 56 17-2 09

E-mail: [info@ott-hydrometry.com](mailto:info@ott-hydrometry.com)  
Internet: [www.ott-hydrometry.com](http://www.ott-hydrometry.com)

We reserve the right to make technical improvements.

Document number  
24.320.000.B.E 03-1003