

# Operating Instructions

## Universal Current Meter **C31**

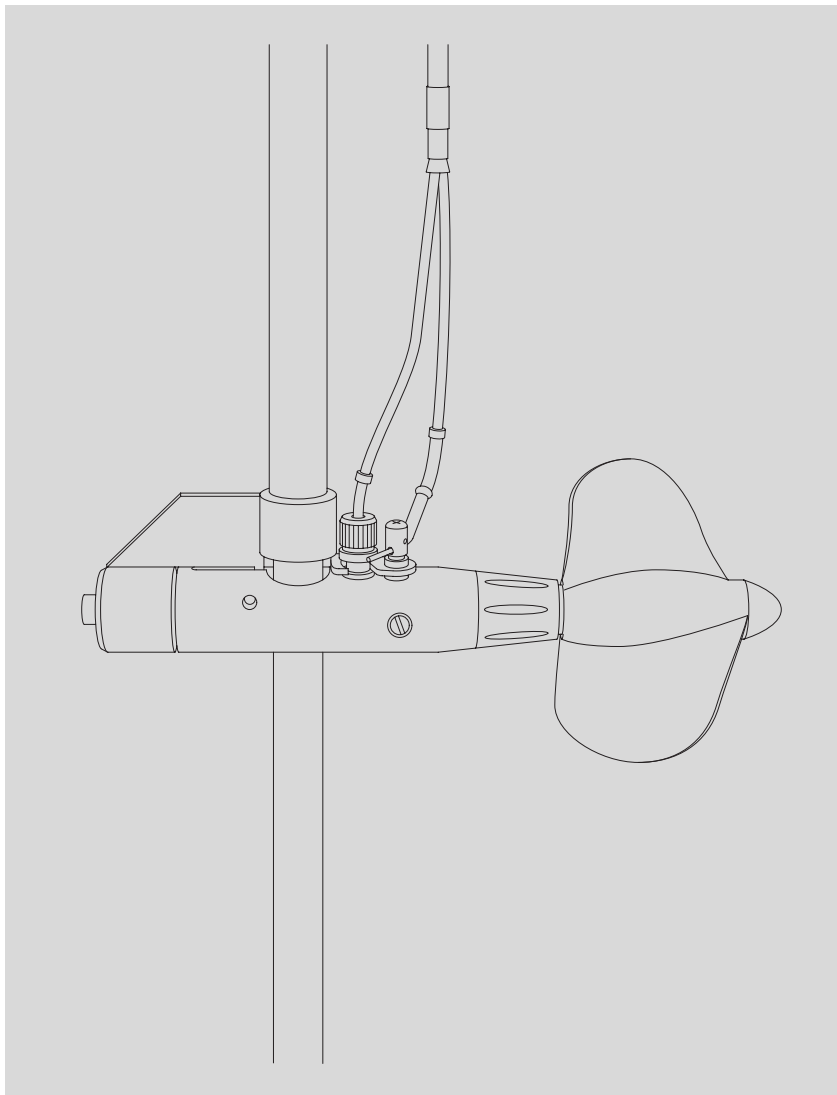

English

We reserve the right to make technical changes!

The universal current meter is used for measuring the flow velocity of water in rivers, open drainage systems and pipelines. It can be attached to rods, cable winches, or cable-way installations.

### Design

The meter body (1) is of cylindrical shape and made of nickel-plated brass.

Signals are generated virtually without power by an impulse device (5) actuated by a magnet (2) which is mounted in the sleeve (3) of the propeller (4). The impulse device emits a pulse on each revolution of the propeller. The encapsulation of the impulse device is completely watertight and pressure-tight, thus allowing reliable measurements to be obtained even in waters chemically aggressive, heavily soiled, or mixed with sand and bed load.

The voltage must not exceed 9 volts d.c.. If effective spark quenching is provided in the indicating and counter sets, the impulse device can be loaded with about 1.6 watts. The indicating and counter sets of our make meet this requirement.

The propellers required for metering revolve on a rugged, stationary stainless steel shaft (8) which has the advantage as against a revolving shaft that slight deformations due to improper handling of the current meter will not impair metering accuracy.

If the propeller should become seriously deformed due to wrong handling or during metering operations, its geometric shape should be checked by inserting it in a bipartite plaster model, which can be obtained from us on order.

The oil-filled hub of the propeller (4) runs on two stainless steel ball bearings (10) which are protected from the ingress of water by a frictionless gasket designed on the capillary principle thus ensuring smooth running. The ball bearings are interchangeable and can be replaced without the constant of the propeller undergoing any change.

## Servicing

- I. The current meter is a precision instrument and should be handled with due care in order to ensure high metering accuracy.

The electrical impulse device operates without any need for servicing. If a circuit discontinuity should nevertheless develop, check whether broken wires, exhausted batteries, defective contact points at the line terminals, plugs, etc., may not be the source of the trouble. Contact trouble very seldom develops in the current meter itself except in the case of wrong treatment such as applying inadmissibly high voltage, etc.

If the impulse device of the current meter is found to be defective, the trouble may be remedied in the following manner:

1. Loosen screw (9) and remove propeller (4) along with steel shaft (8).
  2. Loosen screw connection (7) with stud wrench and remove it, detach O-ring (6), and remove impulse device (5) from meter body (1).
  3. The reverse procedure should be followed when inserting the new impulse device.
- II. The OTT special propeller oil filled into the hub of the propeller (4) allows metering operations at different water temperatures without affecting the metering accuracy. The oil should be changed (see Fig. 2) at the end of each metering operation or whenever the propeller has not been used for a long period.

If the ball bearings become fouled with dirt due to carelessness when changing the oil, they should be dismantled (see Fig. 3) and cleaned in undiluted gasoline (never use any other type of cleaning solvent).

If the ball bearings have to be replaced by new ones after the current meter has been in service over a long period, the procedure indicated in Fig. 3 should likewise be followed. Then place nut (11) on properly and tighten it. In doing so, the steel shaft (8) should preferably be held in the meter body (1) as indicated in Fig. 3. After assembly, remove the protective grease from the ball bearings with undiluted gasoline.

- III. Rinse the current meter after every application in clear water and dry it carefully. Store it in the designated wooden box at a dry storage place. In order to avoid corrosion, do not store the current meter in the adjacency of lead batteries.

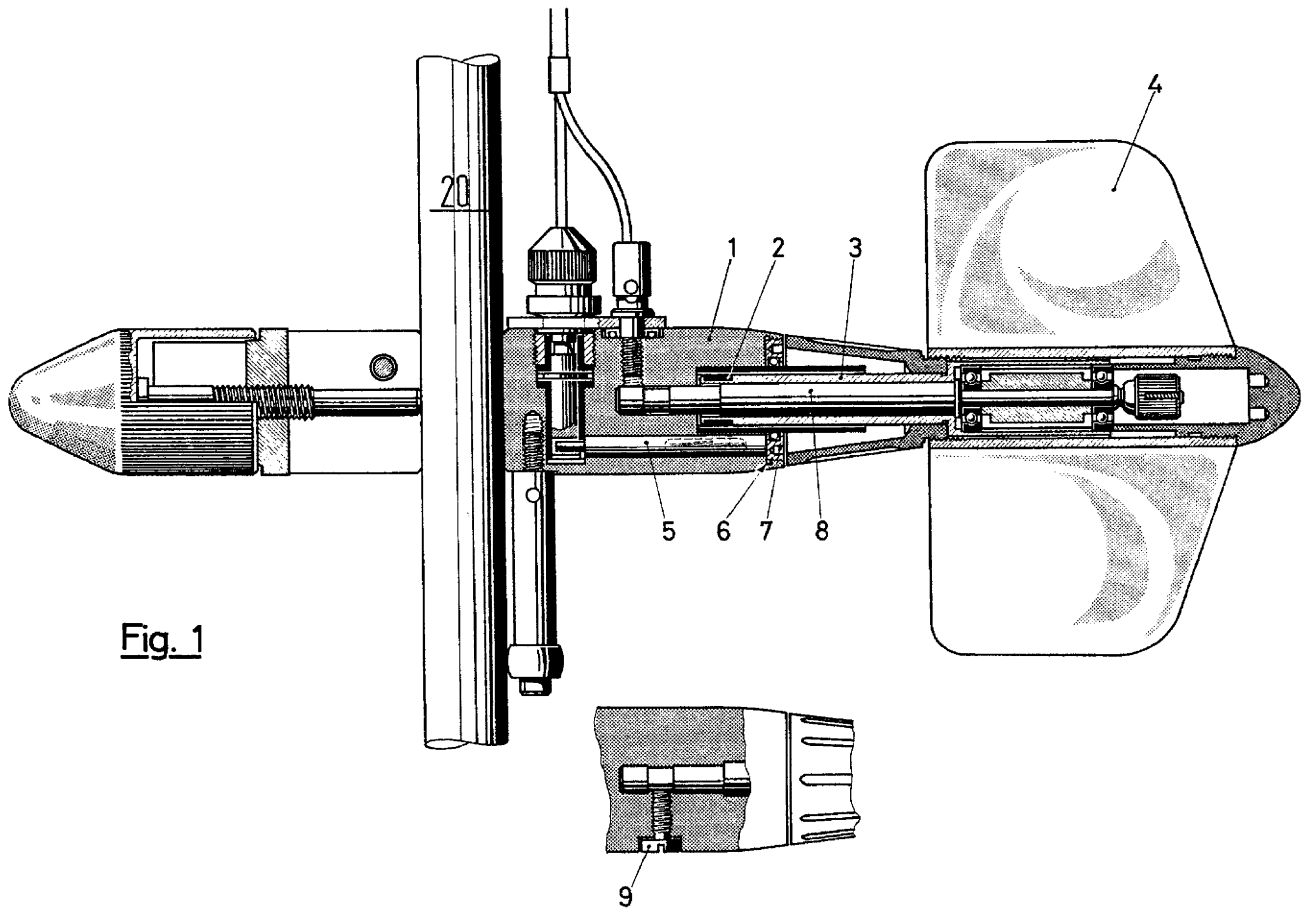

Fig. 1

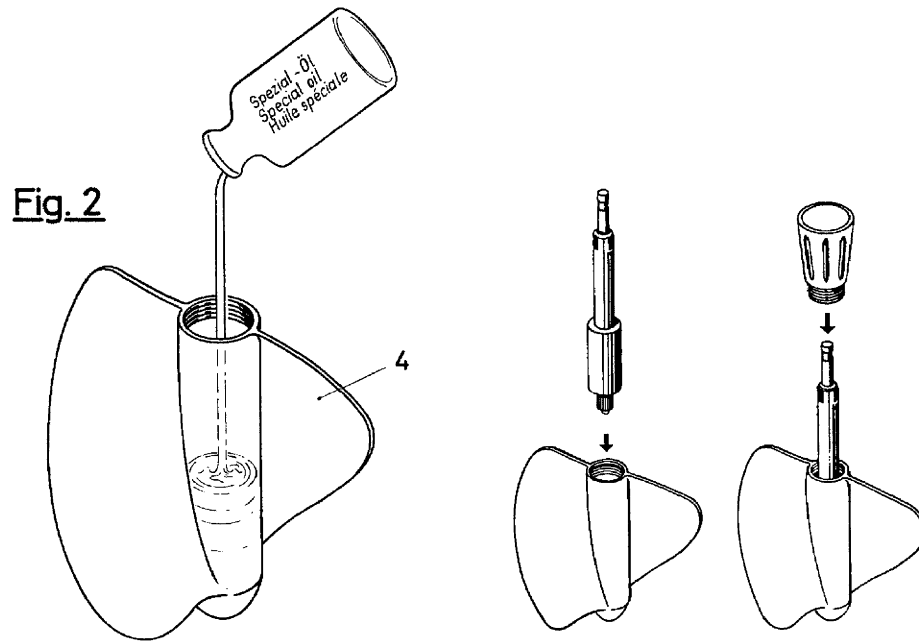

Fig. 2

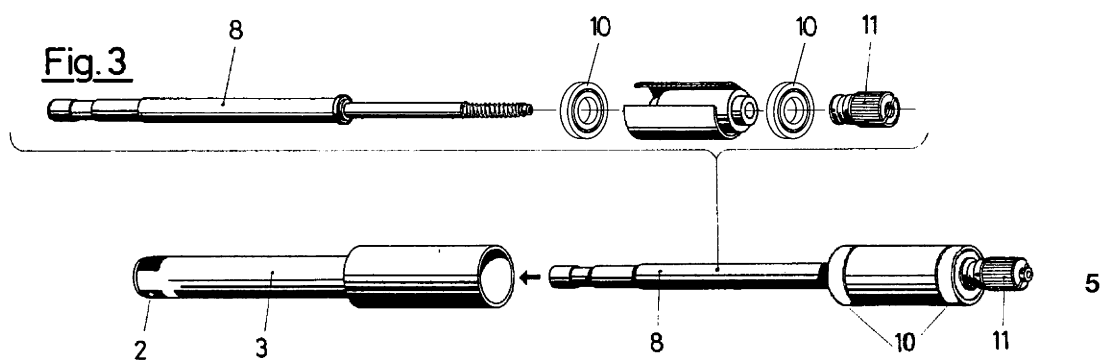

Fig. 3





Document number  
10.001.001.B.E 03-1004

**OTT MESSTECHNIK GmbH & Co. KG**

Ludwigstrasse 16  
87437 Kempten · Germany  
Phone +49 (0)8 31 56 17-0  
Telefax +49 (0)8 31 56 17-2 09

[info@ott-hydrometry.com](mailto:info@ott-hydrometry.com)  
[www.ott-hydrometry.com](http://www.ott-hydrometry.com)